



EL-N series

EL-S-60N

Product characteristics

- Integrated overload protection
- Protective switch inclusive
- High quality plastic housing
- Compact design
- Optional with fault alarm lamp and integrated signal cable
- Connecting hose included in delivery

Dimensions

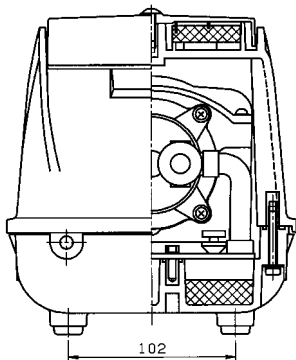
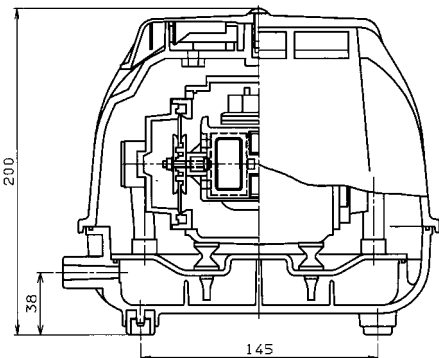

Technical data

Model			EL-S-60N
Air flow ¹⁾	l/min	0 mbar	98
		50 mbar	88
		100 mbar	76
		150 mbar	64
		200 mbar	52
		250 mbar	40
Voltage ²⁾	VAC		230
Power consumption	W	200 mbar	48
Noise level	dB(A)		43
Dimensions	mm	L x W x H	221 x 177 x 200
Connection	mm	Ø outside	19
Net weight	kg		4.4

¹⁾ Product performance may vary +/- 10% from performance curves

²⁾ Values at 50 Hz

Performance data

Optimal operating span

